















300x320 A-CNC-R 27x0,9

	 0°	 45°	 60°	 45°	 60°	 $\begin{matrix} b \\ a \times b \end{matrix}$
	300	290	200	x	x	x
	320x290	260x280	180x170	x	x	320x160
						
3x400V 50 Hz	2,4	20-100	3660x27x0,9	904		
L	B	Hmin	Hmax	V		
2410	1920	1503	2020	800		



STANDARD OPTION

300-F

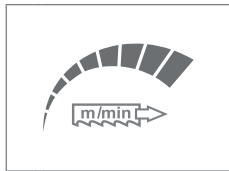

300-PUD

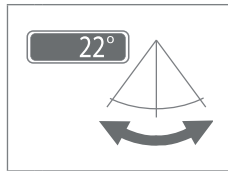

300-PCK

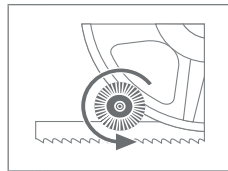

300-DPP

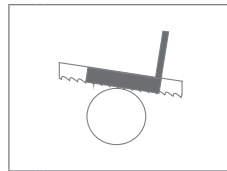

PEGAS-BRP

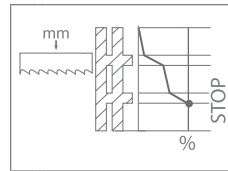

300-RTS-A

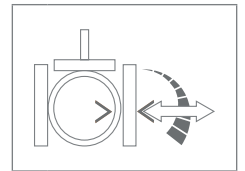

MITSUBISHI HMI 7"

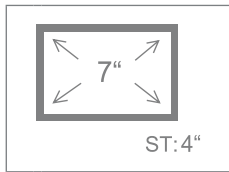

LIGHT L1

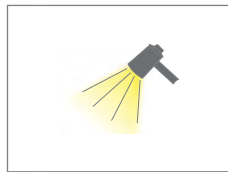

300x320-HP-A

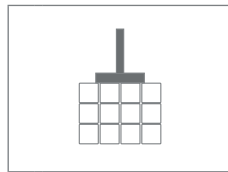

MINI LUBE 27-34

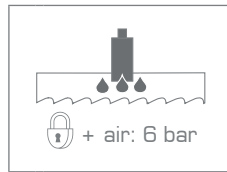

LASER LINE

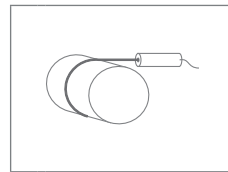

R 390

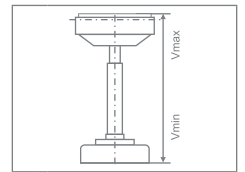

	S (mm)	Vmin (mm)	Vmax (mm)
R	390	760	980

RD VR-390



RB 200



RBS 200/390
+RB



RHS 390
+RBS+RB



300-VTT



RD 2000/390

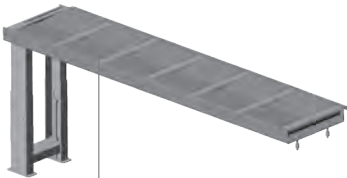

RD 1000/390

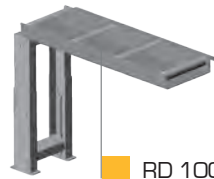

RDN



300-SKZ

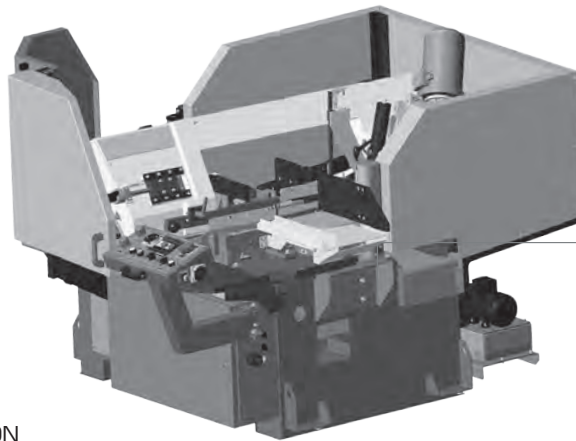

300-LR-RDZ



300x320-RBS



300x320-RB



V-350



300x320-RDZ 1000/350



BOX-TRI



BOX-PCS



BOX-TAH



RDT 2000/350

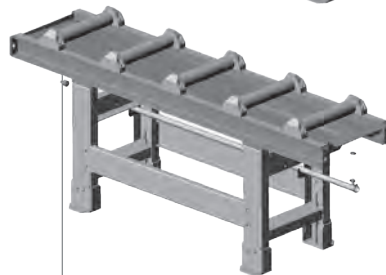

RDT 1000/350



300x320 A-CNC-R



CONTROL PANEL: MITSUBISHI NC

- výrobce si vyhrazuje právo provádět změny technických údajů, technické údaje odpovídají 1.1.2023 / producer has the right to make changes of technical data, technical data are valid on 1.1.2023

- pila na fotografii není vždy v základním provedení, uvedené rozměry odpovídají stroji v základním provedení / the machine in the picture is not always in the basic version, mentioned diameters are for machine in basic version

* doporučená hodnota. Při překročení doporučeného maximálního průměru není možné garantovat výkon pilového pásu!

/ recommended value. The blade performance cannot be guaranteed when the recommended diameter is exceeded!

☒ - řezání svazků bez horního přitlačení / cutting of the bundle without top clamping



PEGAS - GONDA s.r.o.
Čs.armády 322, 684 01 Slavkov u Brna,
CZECH REPUBLIC

www.pegas-gonda.cz
00420-544 221 125 (126) | pegas@gonda.cz