



230x280 GH-LR / **27x0,9**

	0°	45°	60°	45°	60°	$\begin{matrix} b \\ a \times a \times b \end{matrix}$
\odot	230	190	120	185	x	x
\square	280x220	180x170	120x90	180x120	x	280x120
	3x400V 50 Hz	kW	m/min	mm	kg	
	0,9/1,4	35/70	2720x27x0,9	320		
L	B	Hmin	Hmax	V		
1600	890	1320	1950	787		



230x280
GH-LR

STANDARD OPTION

230-M2V

240-CK

MINI LUBE 27-34

LASER LINE

R 290

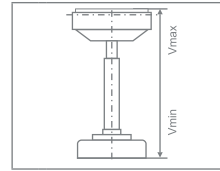
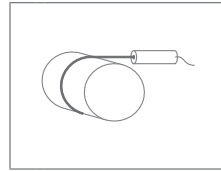
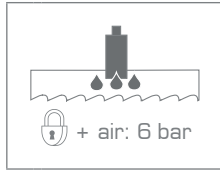
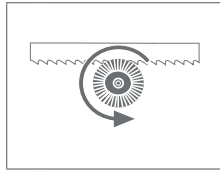
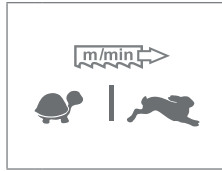

	S (mm)	Vmin (mm)	Vmax (mm)
R	290	760	980

RB 200

RBS 200/290
+RB

RHS 290
+RBS+RB

OZD 1000

OZD 2000
OZD 3000
OZD 4000
OZD 5000
OZD 6000

OZ 1000

OZ 2000
OZ 3000
OZ 4000
OZ 5000
OZ 6000

OZ 0000



230-RDP

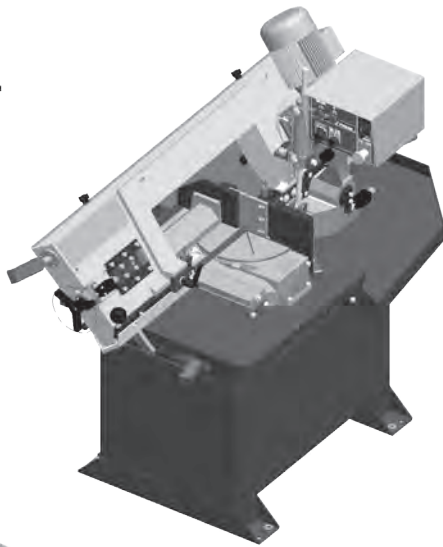

230-OZM

RD VR-290



230-RDZ



RDN



RD 2000/290

BOX-PCS



BOX-TRI



BOX-TAH



RD 1000/290

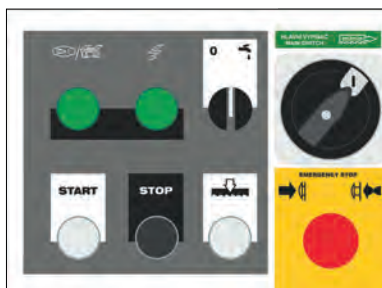

CONTROL PANEL: GH-LR

230x280 GH-LR

- výrobce si vyhrazuje právo provádět změny technických údajů, technické údaje odpovídají 1.1.2023 / producer has the right to make changes of technical data, technical data are valid on 1.1.2023

- pila na fotografii není vždy v základním provedení, uvedené rozměry odpovídají stroji v základním provedení / the machine in the picture is not always in the basic version, mentioned diameters are for machine in basic version

* doporučená hodnota. Při překročení doporučeného maximálního průměru není možné garantovat výkon pilového pásu!

/ recommended value. The blade performance cannot be guaranteed when the recommended diameter is exceeded!

- řezání svazků bez horního přitlaku / cutting of the bundle without top clamping



PEGAS - GONDA s.r.o.
Čs.armády 322, 684 01 Slavkov u Brna,
CZECH REPUBLIC

www.pegas-gonda.cz
00420-544 221 125 (126) | pegas@gonda.cz